



- Height 16,2 mm
- IP 40 or IP 67
- For PCB and sockets (1C/O)
- Accessories: sockets and modules for 1C/O
- Recyclable packing

Contacts

Contact number & arrangement		1C/O, 1NO, 1NC
Contact material		AgCdO , AgSnO ₂ , AgSnO ₂ /Au 3 μm
Max. switching voltage	AC/DC	400 V / 250 V
Min. switching voltage		10 V AgCdO, 10 V AgSnO ₂ , 5 V AgSnO ₂ /Au 3 μm
Rated load	AC1	8 A / 250 V AC
	DC1	8 A / 24 V DC
Min. switching current		5 mA AgCdO, 10 mA AgSnO ₂ , 2 mA AgSnO ₂ /Au 3 μm
Max. inrush current		15 A
Rated current		8 A
Max. breaking capacity	AC1	2 000 VA
Min. breaking capacity		0,5 W AgCdO, 1 W AgSnO ₂ , 0,05 W AgSnO ₂ /Au 3 μm
Resistance		≤ 100 mΩ
Max. operating frequency		
• at rated load	AC1	600 cycles/hour
• no load		72 000 cycles/hour

Coil

Rated voltage	DC	5...48 V
Must release voltage		DC: ≥ 0,1 U _n
Operating range of supply voltage		see Table 1
Rated power consumption	DC	0,3 W

Insulation

Insulation category		C250
Insulation rated voltage		400 V AC
Dielectric strength		
• coil - contact		4 000 V AC
• contact - contact		1 000 V AC
Contact - coil distance		
• clearance		≥ 8 mm
• creepage		≥ 8 mm

General data

Operating time (typical value)		10 ms
Release time (typical value)		5 ms
Electrical life		
• resistive AC1		> 10 ⁵ 8 A, 250 V AC
• cos φ		see Fig. 3
Mechanical life (cycles)		> 2 x 10 ⁷
Dimensions (L x W x H)		28(30-1C/O) x 10 x 16,2 mm
Weight		11 g
Ambient temperature		
• storing		-40...+85 °C
• operating		-40...+80 °C
Cover protection category		IP 40 or IP 67
Shock resistance		20 g
Vibration resistance		10 g 10...150 Hz
Solder bath temperature		max. 270 °C
Soldering time		max. 5 s

Standard contact material marked with bolt type.



Coil data - DC voltage version

Table 1

Coil code	Rated voltage V DC	Coil resistance ± 10% at 20 °C Ω	Coil operating range at 20 °C V DC	
			min.	max.
1005	5	110	3,5	12,0
1006	6	160	4,2	14,5
1009	9	360	6,3	22,0
1012	12	660	8,4	29,5
1018	18	1 500	12,6	44,0
1024	24	2 200	16,8	54,0
1048	48	8 000	33,6	102,0

Standard coil rated voltages marked with bold type.

Dimensions

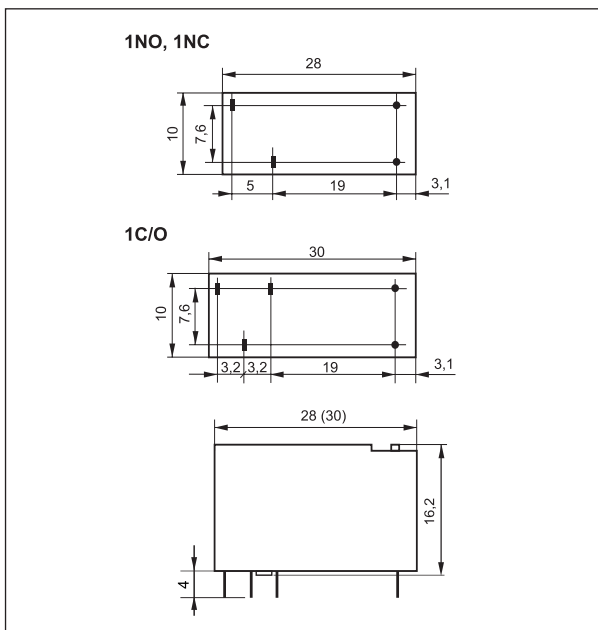

Connections diagram (pin side view)

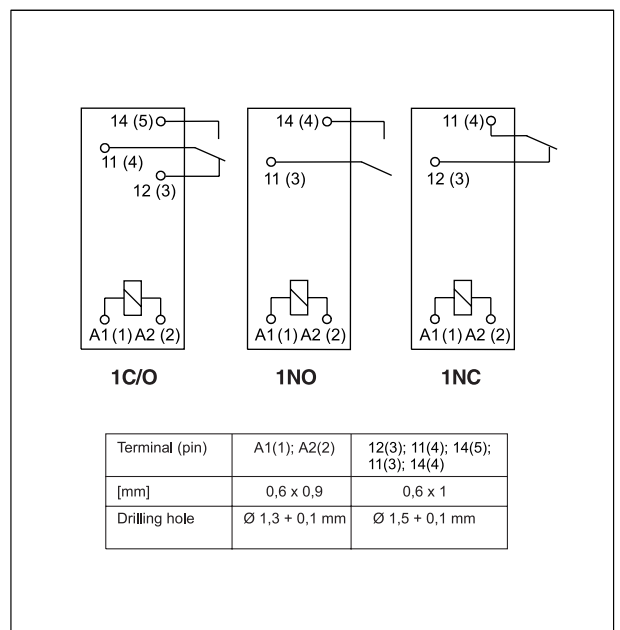

Max. AC and DC resistive load breaking capacity

Fig. 1

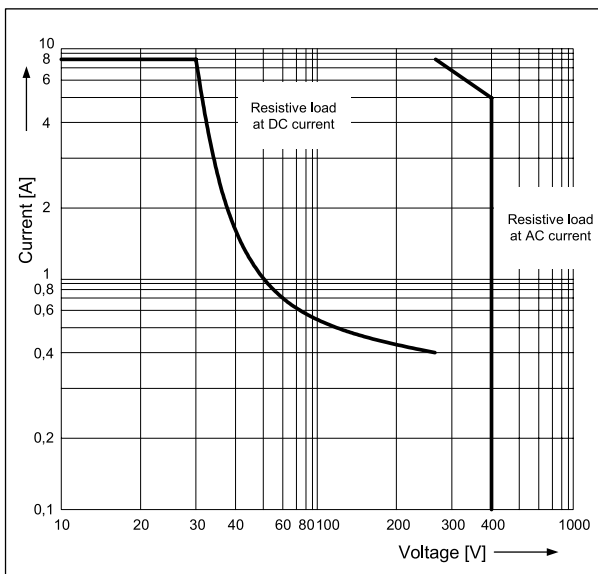

Electrical life at AC resistive load (NO version)

Fig. 2

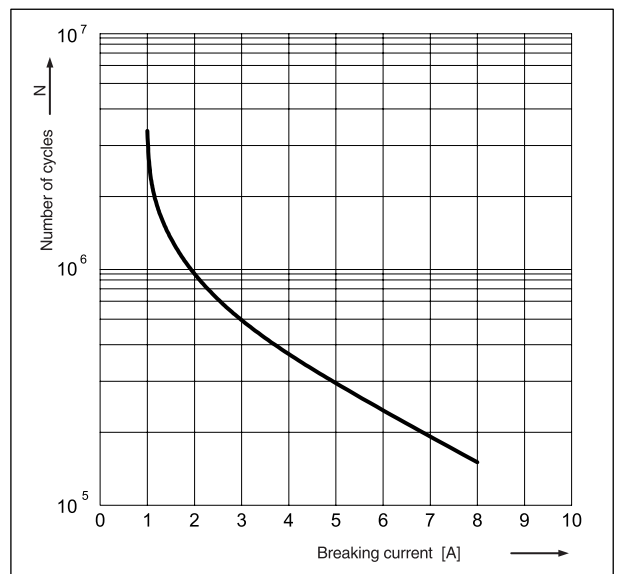

Electrical life reduction factor at AC inductive load

Fig.3

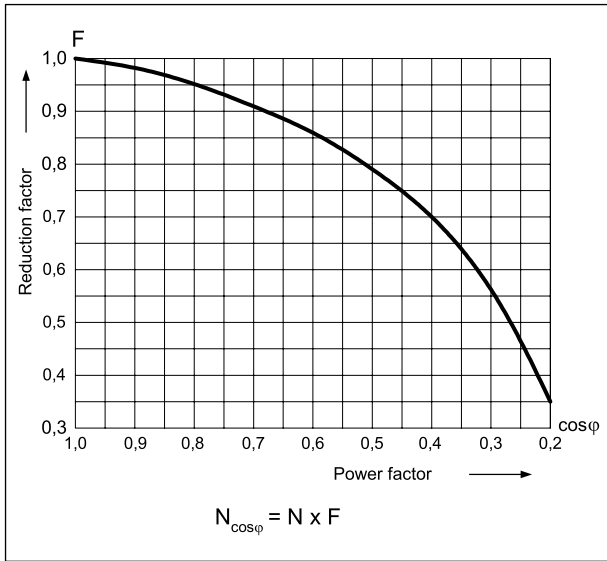

Mounting

Relays **RM96 1NO** and **RM96 1NC** are mounted only on PCBs.

Relays **RM96 1C/O** are designed for: • direct PCB mounting • screw terminals sockets **GZ96** with clip **MS16**, 35 mm DIN rail mount, EN 50022 or on panel mounting. **M...** type signalling and protection plug-in modules are available with sockets (see page 170) • terminals sockets for PCB mounting **GW96** with clip **MH16-2**.

Ordering codes

